

DLV Depositor



DLV Depositor

Accuracy and versatility

The new lobe depositor model DLV has been designed to meet the needs of the modern food industry that requires versatile machines to satisfy a market that is ever more demanding and changing.

The DLV Depositor features the innovative depositing system with individual lobe pumps (ILPS)* and feed rollers for the optimal filling of the chambers. These ensure that the machine is capable of accurately depositing a wide range of batters, fluids, dense and aerated mixes, and even batters containing small particulates, such as nuts, chocolate, candied fruit, etc.

All the machine functions are PLC-controlled and the working parameters relating to each product are easily

programmable and can be stored for re-use by the operator through a simple interface panel.

The DLV depositor complies with current hygienic-sanitary and security standards: hopper, feed rollers, lobe pumps and nozzles are easily removable for thorough cleaning, while the main structure can be pressure-washed with water. All the moving parts are protected with stainless steel guards fitted with safety switches. Many types of trays can be used: plain or indented - made of metal, cardboard or plastic. The working speed is 30 cycles/min. for spot depositing and 40 cycles/min. for wire-cut applications.

(*) Individual Lobe Pumps System.



DLV Depositor

Options and accessories

The DLV depositor is available in three working widths: 460, 620 and 800 mm.

The lobe pump assembly (ILPS)* is easily interchangeable and can be supplied with the number of outlets required by the customer.

The machine can be equipped with the following accessories:

- Wire cut unit;
- Twist device;
- Dosing plates having pneumatic anti-drip nozzle shut off.

On request, this machine can be supplied without a conveyor for use on existing lines or make-up tables.

(*) Individual Lobe Pumps System.

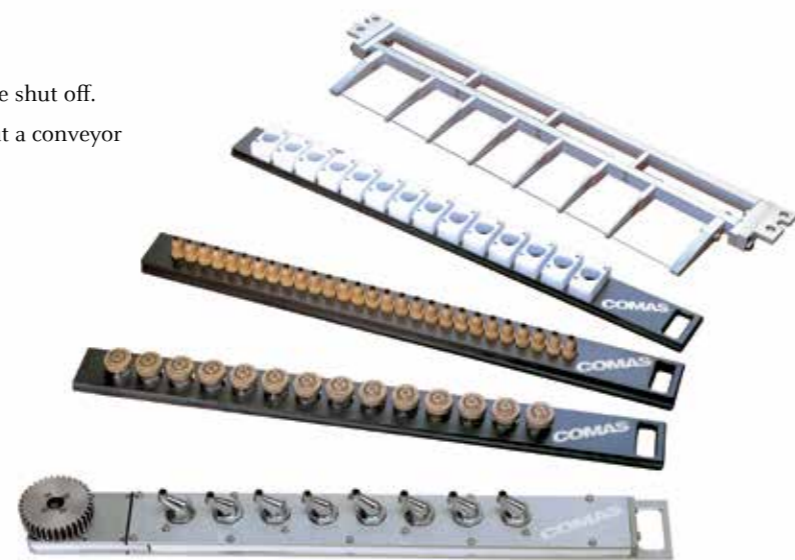

Compact lobe depositor on wheels

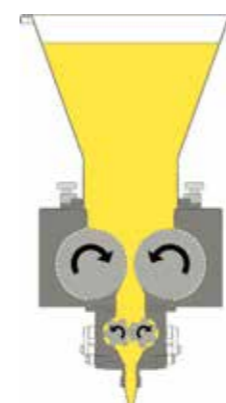
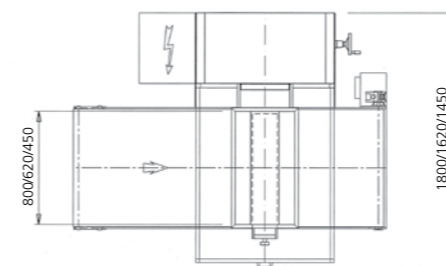
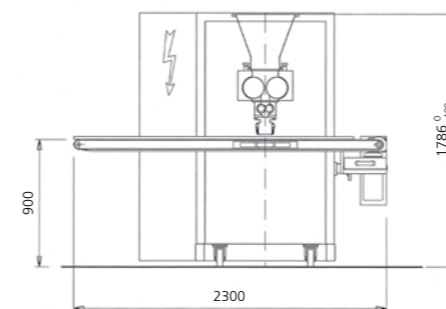

Depositing concept

The depositing head is made up of a pair of motorized rollers feeding the volumetric lobe pumps underneath (a separate one for every outlet), which in turn deposit the mix with extreme accuracy across the whole working width.



As well as the production of wire cut biscuits and smooth batters on trays, the DLV model lobe depositor can deposit cakes or fillings. Test it in our Bakery Experience Centre (BEC) supported by our food technologist.



DLV Depositor



| | |
|---------|-------|
| ∅ 8 mm | DRT 1 |
| ∅ 10 mm | DRT 2 |
| ∅ 12 mm | DRT 3 |



| | |
|---------|--------|
| ∅ 8 mm | DRT 13 |
| ∅ 10 mm | DRT 14 |
| ∅ 12 mm | DRT 15 |



| | | | |
|---------|--------|--------|--------|
| | 20 mm | 25 mm | 30 mm |
| ∅ 8 mm | DRT 4 | DRT 5 | DRT 6 |
| ∅ 10 mm | DRT 7 | DRT 8 | DRT 9 |
| ∅ 12 mm | DRT 10 | DRT 11 | DRT 12 |



| | | | |
|---------|--------|--------|--------|
| | 20 mm | 25 mm | 30 mm |
| ∅ 8 mm | DRT 16 | DRT 17 | DRT 18 |
| ∅ 10 mm | DRT 19 | DRT 20 | DRT 21 |
| ∅ 12 mm | DRT 22 | DRT 23 | DRT 24 |



Nozzles for dropped products



Patterns for wire-cutter

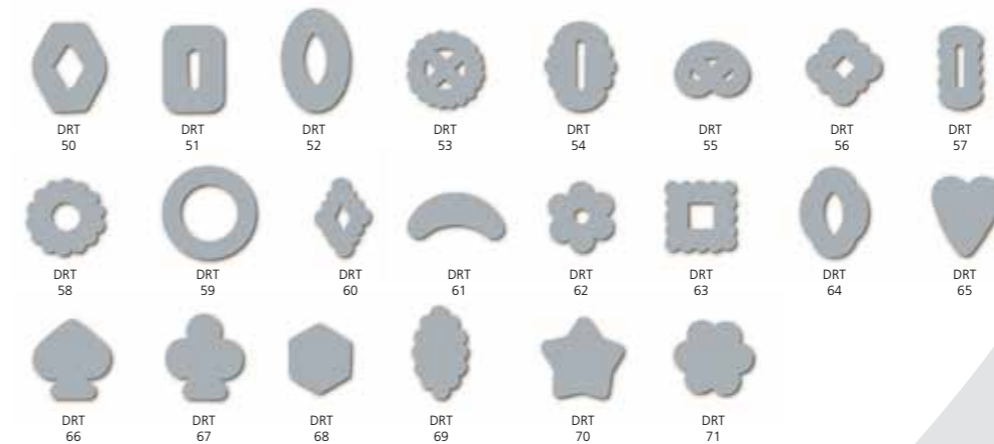



We live our values.

Excellence • Passion • Integrity • Responsibility • GEA-versity

GEA is a global technology company with multi-billion euro sales operations in more than 50 countries. Founded in 1881 the company is one of the largest providers of innovative equipment and process technology. GEA is listed in the STOXX ® Europe 600 Index. In addition, the company is listed in selected MSCI Global Sustainability Indexes.

GEA Comas

Viale dell'industria 12
36015 Torrebelvicino, Italy

Tel +39 0445 660 222
Fax +39 0445 661 534

gea.com/contact
gea.com